

INSTALLATION INSTRUCTION

Item# 5682/5683/5684

READ AND SAVE THESE INSTRUCTIONS

WARNING! SHUT POWER OFF AT FUSE OR CIRCUIT BREAKER .
AVERTISSEMENT! COUPER LE COURANT AU NIVEAU DES FUSIBLES OU DU DISJONCTEUR.

PREPARATION

1. Shut off the power at the circuit breaker box and, if necessary, remove the old fixture, including the mounting hardware.
2. Carefully unpack your new fixture and lay out all the parts on a clear area. Take care not to lose any small parts necessary for installation.

MOUNTING THE FIXTURE (Fig.1)

3. Thread two mounting screws (A) (Size: #8-32*1.2"L) into circular strap (B) spaced same distance apart as holes in back plate (D). Length of mounting screws (A) into circular strap (B) may be adjusted if necessary. Attach circular strap (B) to junction box (Not included) using junction box screws (C) (Size: #8-32*0.6"). The side of circular strap (B) marked "GND" must face out.

CONNECTING THE WIRES (Fig. 2)

4. Connect the electrical wires as shown in Fig. 2, Making sure all wire connectors are secured. If your outlet box has a ground wire (green or bare copper) connect fixture's ground wire to it. Otherwise, connect fixture's ground wire directly to the circular strap using green screw provided.
5. After the wires are connected, tuck them neatly inside the junction box.

COMPLETING THE INSTALLATION (Fig. 1)

6. Align back plate (D) onto circular strap (B), and secure with ball nuts (E).
7. Put the socket cap (G) onto the glass shade (I) and tighten it using the screws (H). Do not over tighten.
8. Place glass shade (I) with socket cap (G) over the socket (F) and secure with the socket ring (J). Do not over tighten.
9. Install (2) two medium base bulbs for 5682 and (3) three medium base bulbs for 5683 and (4) four medium base bulbs for 5684 up to 60 watts each or CFL or LED equivalent (not included) in accordance with the fixture specification. **(DO NOT EXCEED THE SPECIFIED WATTAGE!) (NE PAS DEPASSER LA PUISSANCE NOMINALE MAXIMALE!)**

Fig.1

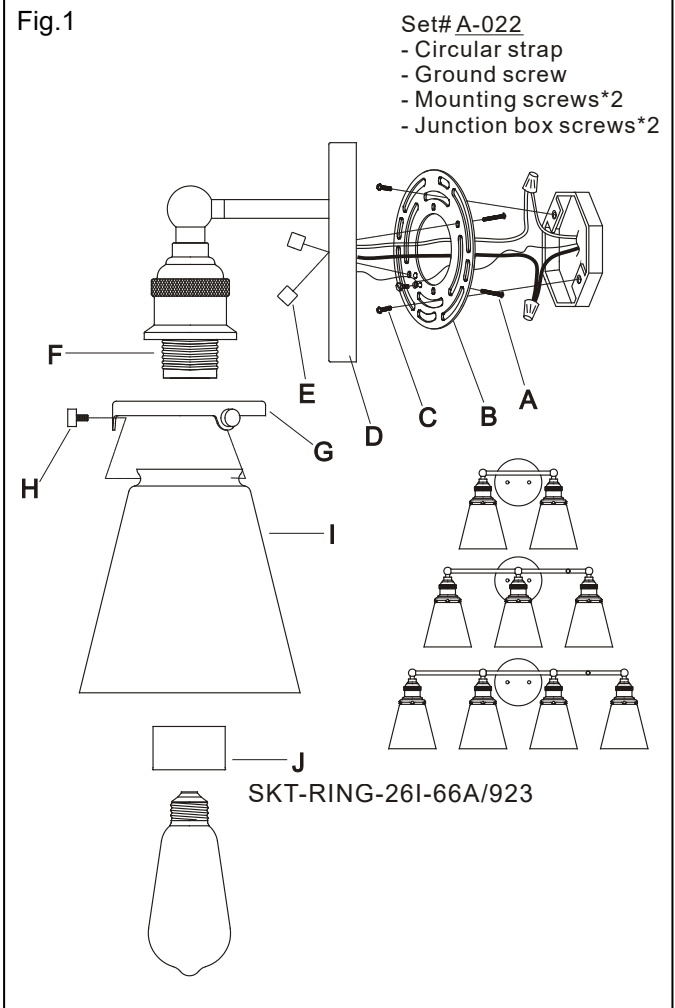
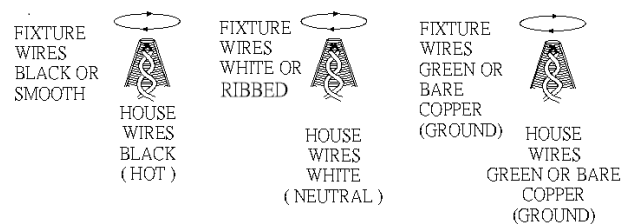

Fig.2



Your installation is now complete. Return the power to the junction box and test the fixture.

