

INSTALLATION INSTRUCTIONS

Model #73116

READ AND SAVE THESE INSTRUCTIONS

WARNING! SHUT POWER OFF AT FUSE OR CIRCUIT BREAKER.

AVERTISSEMENT! COUPER LE COURANT AU NIVEAU DES FUSIBLES OU DU DISJONCTEUR.

PREPARING FOR INSTALLATION (Fig. 1)

1. Shut off the power at the fuse box or circuit breaker box and remove the old fixture, including the mounting hardware.
2. Carefully unpack your new fixture and lay out all the parts in a clear area. Take care not to lose any small parts necessary for installation.
3. Pull the black, white, and ground wires out of base of the post (A).

CONNECTING THE WIRES (Fig. 2)

4. While supporting the fixture, connect the electrical wires as shown in Fig. 2. If your post has a ground wire (green or bare copper), connect the fixture ground wire to it. If not, consult your electrician for proper grounding (Fig.2). After wires are connected, tuck them carefully inside the post cup (A) (not included).

COMPLETING THE INSTALLATION (Fig. 1)

5. Align the lantern (C) with post (A) and secure with screws (B). (Fig.1)
6. Unscrew the nuts (D) and remove frame (I).
7. Install (1) one medium base bulb (E) up to 60 watts or CFL or LED equivalent (not included) in accordance with the fixture specification.

**DO NOT EXCEED THE MAXIMUM WATTAGE RATING!
(NE PAS DEPASSER LA PUISSANCE NOMINALE
MAXIMALE!)**

8. Install frame (I) and secure with the nuts (D).

Your installation is now complete. Return power and test the fixture.

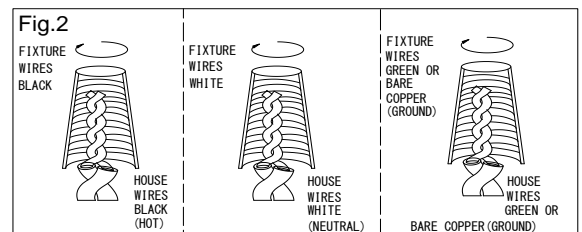
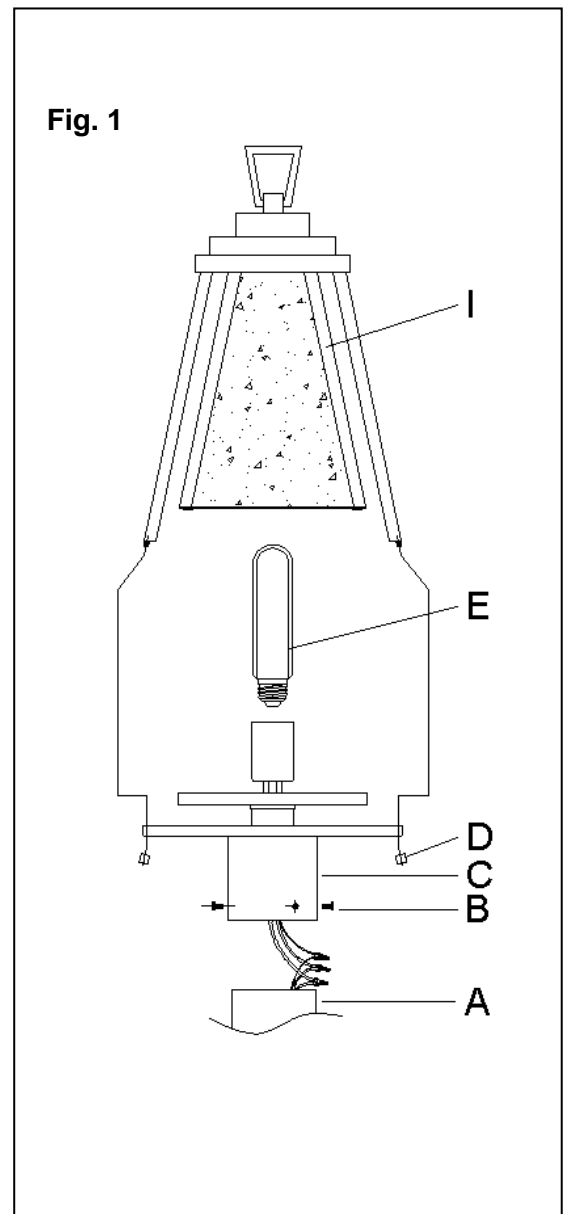

“CAUTION-RISK OF FIRE CONSULT A QUALIFIED ELECTRICIAN TO ENSURE CORRECT BRANCH CIRCUIT CONDUCTOR”

ATTENTION – RISQUE D’INCENDIE, CONSULTER UN ÉLECTRICIEN QUALIFIÉ POUR VOUS ASSURER QUE LES CONDUCTEURS DE LA DÉRIVATION SONT ADÉQUATS.

