

INSTALLATION INSTRUCTIONS

Item#P1784-720/721-L (New. 02/11/2019)

READ AND SAVE THESE INSTRUCTIONS

WARNING! SHUT POWER OFF AT FUSE OR CIRCUIT BREAKER.

AVERTISSEMENT! COUPER LE COURANT AU NIVEAU DES FUSIBLES OU DU DISJONCTEUR.

PREPARATION (Fig. 1)

1. Shut off power at the fuse box or circuit breaker box and remove the old fixture including the mounting hardware.
2. Carefully unpack your new fixture and lay out all the parts in a clean area. Take care not to misplace any small parts necessary for installation.
3. Determine the desired hanging height and thread rods (F1, F2 and F3) to the nipple (H). Pass the wires carefully through each rod as you assemble.
4. Install canopy (D) by screwing top rod into swivel (E).
5. Thread both screws (A) into the pre-drilled holes in the circular strap (B) that are spaced the same distance apart as the holes in the canopy (D).
6. Attach the circular strap (B) to the junction box (not included) using mounting screws (C) (Size: #8-32N*L0.5"). Note: The side of the circular strap marked "GND" must face out.
7. The support cable (I) is provided to support the weight of the fixture while wiring. Align the fixture to circular strap (B) and attach hook (J) on the end of support cable (I) into a slot located on circular strap (B). Carefully allow the support cable (I) to support the weight of the fixture while wiring (Fig.1).

CONNECTING THE WIRES (Fig. 2)

8. Connect the electrical wires as shown in Fig.2 making sure that all wire connectors are secured. If your outlet box has a ground wire (green or bare copper), connect the fixture's ground wire to it. Otherwise, connect the fixture's ground wire directly to the circular strap (B) using the green screw provided. Tuck wires neatly back into the junction box.

COMPLETING THE INSTALLATION (Fig. 1)

9. Slide the canopy (D) through the mounting screws (A) and secure with knurled knobs (G).

Your installation is now complete. Return power to the junction box and test the fixture.

Replacing LED module (Fig. 3)

The LED module can be replaced by a qualified electrician without cutting of wire and without damage to any decorative element to which the fixture is attached. See installation steps for more details (Fig 3.)

- a. Shut off the power.
- b. Remove knurled knobs (G). While holding the fixture, disconnect the wire connectors, take hook (J) out of circular strap (B), and then place the fixture body on a clean surface.
- c. Unscrew the lighting assembly (R) as shown Fig. 1 and pull it a distance about 1 foot away from fixture body. (**Note: do not let the end of wire out of canopy**).
- d. Remove three screws (L) and glass (Q).
- e. Press the hole of the printed "L" quick connector on LED module with a pin to disconnected the black wire, and then disconnect the white wire from the printed "N" quick connector on LED module.
- f. Remove coupling (M) and lock washer (N).
- g. Remove screws (O) and carefully remove the LED module (P).
- h. Reverse steps b-g for installing the new LED module. (Before installing lighting assembly (R), twist assembly 4-5 times counterclockwise, so wire straighten out during reassembly.

Note: The LED module should be provided by a specified supplier.

Note: Illustration (Fig. 1) on this manual is for installation purposes only. It may or may not be identical to the fixture purchased.

Dimmable with LED compatible wall dimmer switches.

Fig. 1

Set# A-020
-Circular Strap
-Ground Screw
-Mounting Screw*2

Rod# W30-1-720/721*1(F1)
W30-1-720/721*2(F2)
W30-H-720/721*1(F3)

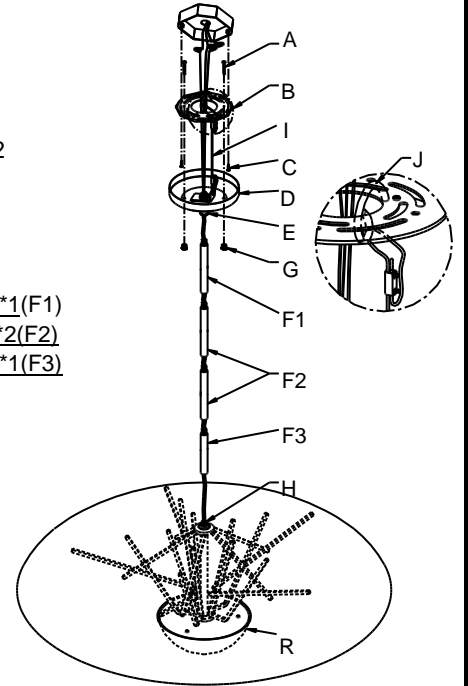

Fig. 2

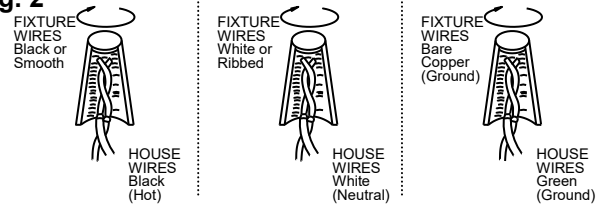
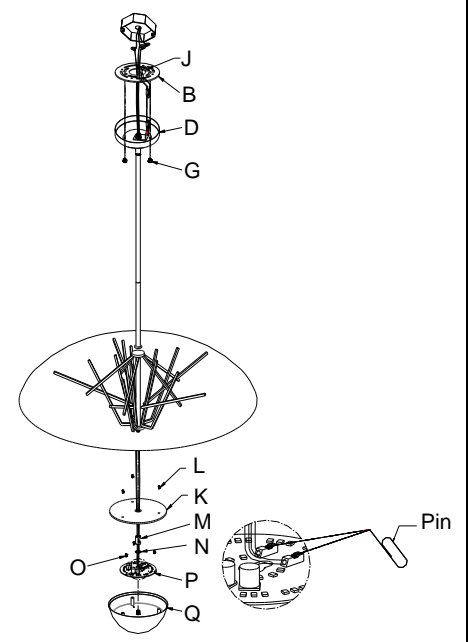

Fig. 3



LA-3081E



american
lighting
association