

INSTALLATION INSTRUCTIONS

Model # 7902 Post

READ AND SAVE THESE INSTRUCTIONS

WARNING! SHUT POWER OFF AT FUSE OR CIRCUIT BREAKER.

AVERTISSEMENT! COUPER LE COURANT AU NIVEAU DES FUSIBLES OU DU DISJONCTEUR.

We recommend that you check your local wiring codes and consult an electrical contractor before installing the post base.

We recommend that the portion of the base that will rest against the concrete be coated with an asphalt base paint due to alkali condition of various concrete mixes and soils which can react to the metallic surfaces and cause corrosion.

SAFETY ALERT!

FIND THE LOCATION OF ANY UNDERGROUND PLUMBING, POWER LINES, AND OTHER LINES BEFORE DIGGING.

1. Dig a hole approximately 16" Dia X 20" Deep (Fig.1).
2. After consulting the local codes, dig a trench to the required depth from the post hole to the power source.

WARNING! SHUT POWER OFF AT FUSE OR CIRCUIT BREAKER
AVERTISSEMENT! COUPER LE COURANT AU NIVEAU DES FUSIBLES OU DU DISJONCTEUR.

3. Install the underground electrical cables. Make sure to leave approximately 10" of lead wires from the concrete surface to allow sufficient leads for splicing purposes (Fig.1).
4. Pour the concrete into the hole making sure the conduit with the electrical wires is kept secured in the center of the hole (Fig.1).
5. Place the template over the fresh concrete and mark the location of the four J-bolt holes (Fig.1).
6. Insert the 4 J-bolts into the fresh concrete and adjust them up or down as needed to keep the ends of the J-bolts approx. 2" above the surface. Finally check to make sure all four J-bolts are straight and properly aligned.
7. After the concrete hardens, thread the hex-nuts (provided) onto the J-bolts. Note: The hex-nuts may be adjusted up or down to assist in leveling the post base.

8. Place the post base over the J-bolts and secure it with the steel washers and cap nuts provided (Fig.3).
9. Secure the top pole into the bottom pole by turning clockwise. (Fig.4)
10. Secure the top and bottom pole assembly into the post base by turning clockwise. (Fig.5) NOTE: To help secure and to prevent water from entering the pole, it is recommended that clear silicone sealant be spread evenly on the threads of the top pole prior to securing into the bottom pole and the bottom pole prior to securing into the post base.
11. Install the light fixture over the post by following the instruction steps from the instruction manual included with the fixture.
12. Remove the access window located at the post base (Fig.3) and follow the wiring instructions included with the light fixture.

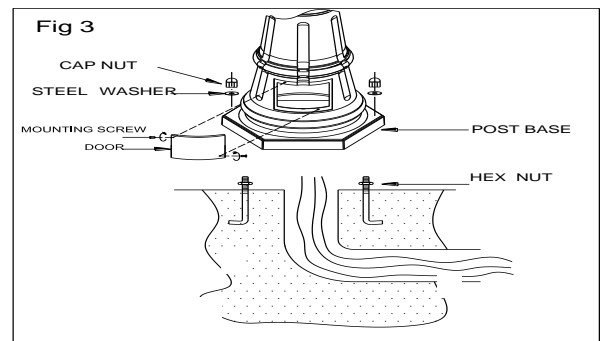
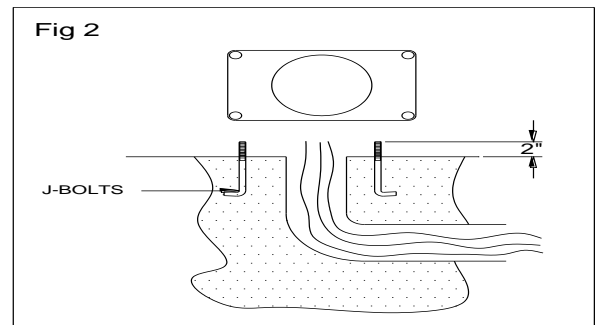
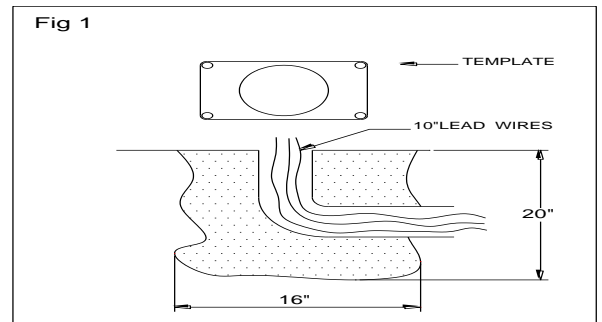

CAUTION: Scratches or chipped paint caused as a result of abuse or by weed eaters, lawn mowers, etc. and or use of certain fertilizers can cause corrosion to steel or aluminum posts.

